

User-defined Coatings and Polarization Ray Tracing are important features, provided by *LightTools*, for modeling a wide variety of illumination systems. This paper describes the theory behind some common coating and polarization effects, and compares the theory with equivalent *LightTools* models for several example systems. *LightTools* models and analysis results are also described in several examples of real world systems.

User-Defined Coatings

The capability to specify multi-layer thin film coating performance characteristics as a surface optical property has been implemented in *LightTools*. This allows the user to specify the transmission and reflection characteristics of a coated surface in terms of ray trace parameters. The ray trace parameters available are wavelength, angle of incidence, and X,Y position on the surface. The transmittance and reflectance of the coating can be specified for the electric field vector components (s and p), or the average transmittance and reflectance of the electric field vector components.

Example 1: Dichroic Optical Coating

A multi-layer dichroic coating is one of the most common coatings found in optics today. These coatings are used in camera lenses, digital projection systems, and semiconductor manufacturing equipment, as well as many other imaging and non-imaging systems. *LightTools* allows a user to specify user-defined coating performance data graphically (as shown in Figure 1a),

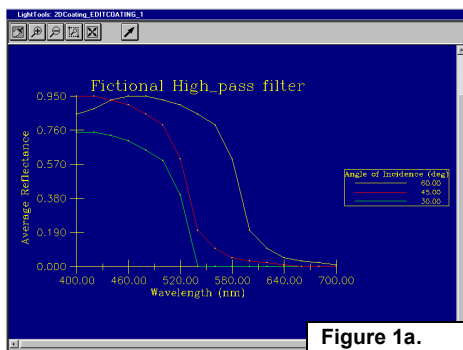

Figure 1a. *LightTools* User-Defined Coating Interface

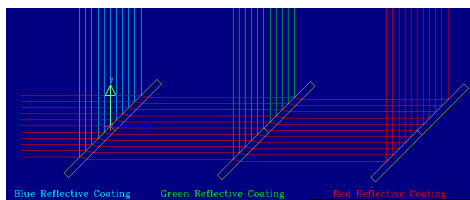

Figure 1b. Dichroic Mirror

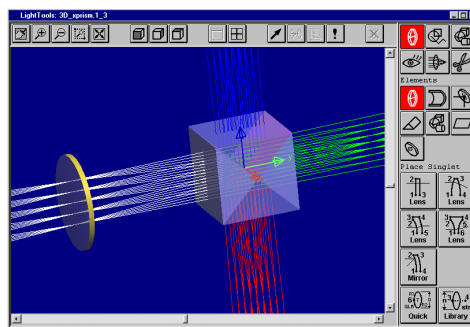

Figure 2. Dichroic Coated X-Prism

numerically within the software, or through an ASCII text file interface.

An example of a series of dichroic coatings is shown in Figure 1b. Light containing red, green, and blue wavelengths is incident on three optical flats, each with a different dichroic coating. The first reflects blue light, but transmits green and red light. The second reflects green light but transmits red light. The third reflects red light.

Example 2: X-Prism

Dichroic coatings similar to those described above can be used to create a simple x-prism. This is a device that can split red, green, and blue light into three separate paths, or recombine red, green, and blue light into one common path. As shown in Figure 2, incident white light can be split into separate red, green, and blue paths.

LightTools is the ideal tool for modeling an x-prism, since it has the required features to create and attach a coating to a surface and the ability to immerse an object inside of another object.

Polarization Ray Tracing

LightTools has the capability to perform ray tracing with polarized, unpolarized, and partially polarized light. Polarizing elements and polarization-dependent optical coatings are also supported. There are three ways to specify the input polarization state of a ray: a geometrical representation in terms of a polarization ellipse, definition in terms of Jones vectors, or definition in terms of Stokes vectors.

These three methods for specifying the input polarization state allow for the

greatest flexibility in the design and analysis of an optical system. Jones vectors can be used for totally polarized light. Stokes vectors can be used for partially or fully polarized light and can easily be defined based on experimental data. Geometrical representation can also be used for partially or fully polarized light and gives the user a tangible geometrical understanding of the polarization state.

The specification of polarizing elements is accomplished with the Ray Amplitude option. The choices for polarizing elements are:

- **Fresnel Loss**—Uses the Fresnel equations for the polarization vector components at an uncoated interface.
- **Ideal Linear Polarizer**—Transmits polarization vector components that are parallel to the transmission axis with 100% efficiency.
- **Ideal Linear Retarder**—Introduces an optical path difference between the polarization vector components.
- **Jones Matrix**—Applies a 2×2 complex matrix to a surface that operates on Jones vectors.
- **Mueller Matrix**—Applies a 4×4 matrix to a surface that operates on Stokes vectors.
- **Scattering Surfaces**—The polarization state of scattered rays can be specified for any of the ray amplitude scattering options.
- **Quarter-Wave AR Coating**—Applies a quarter-wave anti-reflection coating to a surface.
- **User Defined Coating**—Applies user-defined coating performance curve(s) to a surface.

Example 3: Crossed Linear Polarizers¹

In the case of natural or unpolarized light, the instantaneous polarization fluctuates rapidly and in a random manner. An ideal linear polarizer is a device that produces linear polarized light from unpolarized light.

The transmission axis (as noted by the red arrows in Figure 3) of an ideal linear polarizer defines the direction of the

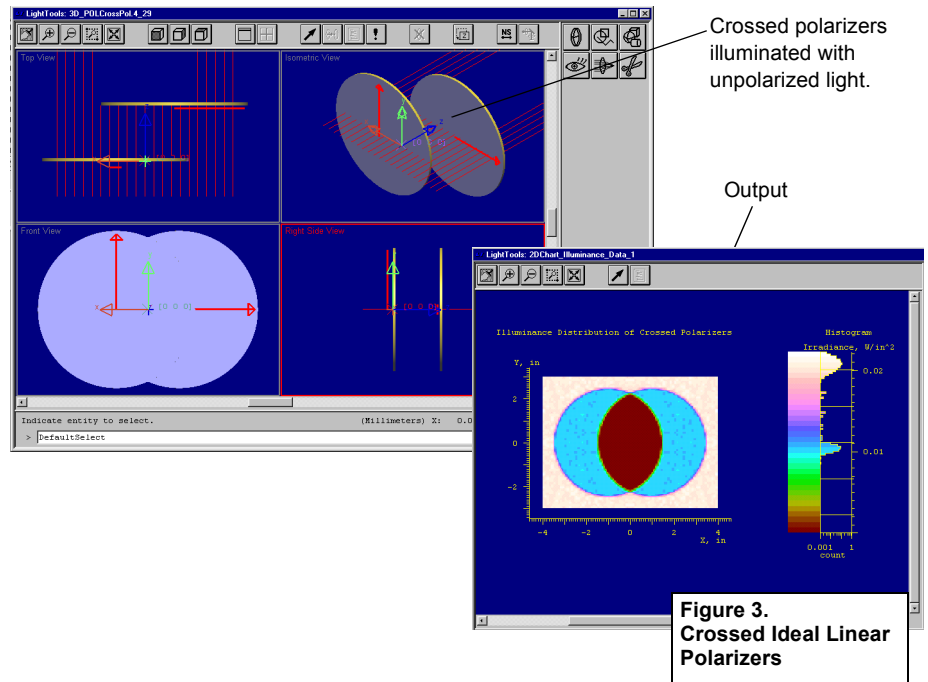

Figure 3. Crossed Ideal Linear Polarizers

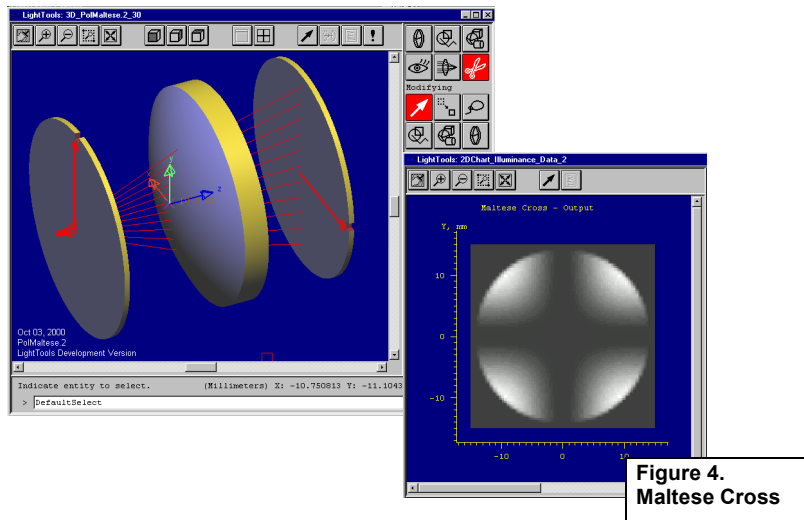

Figure 4. Maltese Cross

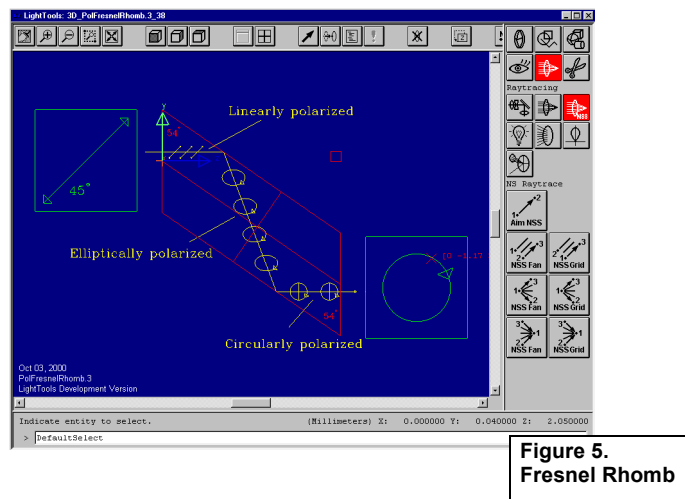

Figure 5. Fresnel Rhomb

electric field vector for a light wave that is transmitted with little or no loss. A light wave whose electric field is at a right angle to the transmission axis is absorbed or attenuated. An ideal polarizer is one that is completely transparent to light linearly polarized in the direction of the transmission axis, and completely opaque to light polarized in the orthogonal direction to the transmission axis.

For unpolarized collimated illumination, two ideal linear polarizers with transmission axes at right angles to one another (crossed polarizers), will absorb all light (as shown in the overlap region of the Figure 3 output). In the region of no overlap, 50% of the light is transmitted. Horizontally polarized light will be present in one of the no overlap regions, and vertically-polarized light will be present in the other.

Example 4: Maltese Cross

As seen in the crossed linear polarizer example above, when the transmission axes of two ideal linear polarizers are “crossed,” light whose electric field component is at a right angle to the transmission axis is absorbed or attenuated. However, for divergent light, the electric field vectors are not at right angles to the transmission axis of two crossed polarizers.

In this case, light that has an electric field vector that is aligned with one of the transmission axes and not perpendicular to the other will be completely absorbed. Light that has an electric field vector that is not aligned with one of the transmission axes (and not perpendicular to the other) will be partially attenuated. Some light will be transmitted as seen in Figure 4. It is the light furthest from the axis and at 45° with respect to the transmission axis of the two polarizers that will exhibit the most transmission through the system, as shown in Figure 4.

Example 5: Fresnel Rhomb²

The Fresnel Rhomb method of changing linearly polarized light to circularly polarized light is shown in Figure 5.

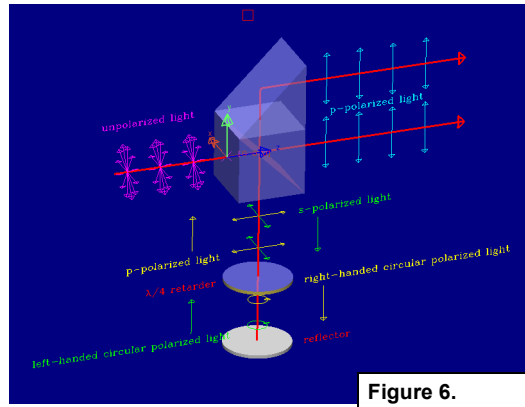

Figure 6. Polarization Beam Splitter³

The essential element is a glass prism made in the form of a rhomb. Linearly polarized light whose polarization is oriented at an angle of 45° with respect to the face edge of the rhomb enters normally on one face (see Figure 5).

The light undergoes two internal reflections and emerges from the exit face. At each internal reflection a phase difference Δ is produced between the s and p polarizations. This phase difference is equal to π/4 for an angle θ of 54° with glass index of 1.5 as calculated in the equation below.

$$\tan \Delta/2 = \frac{\cos \theta \sqrt{\sin^2 \theta - n^2}}{\sin^2 \theta}$$

A total phase difference of π/2 is obtained for the two internal reflections; therefore, the emerging light is circularly polarized.

Example 6: Polarization Beam Splitter

The polarization beam splitter is a classic example of obtaining a single state of polarization through a beam splitter with either most of the energy, or, in the ideal case, all of the energy. As shown in Figure 6, unpolarized light is incident on a cube beam splitter that transmits p linear polarized light and reflects s linear polarized light.

The s linear polarized light passes through a quarter-wave retarder that changes the phase by π/4 to create clockwise circularly polarized light. The clockwise circularly polarized light strikes a mirror that changes the phase by π to create counter-clockwise circularly polarized light. The light then passes back through the quarter-wave retarder, which changes the phase once again by π/4 to create p linearly polarized light. The p-polarized light can now pass through the polarization beam splitter as shown in Figure 6. All of the energy from the original beam has been delivered through the polarizing beam splitter with the same polarization state.

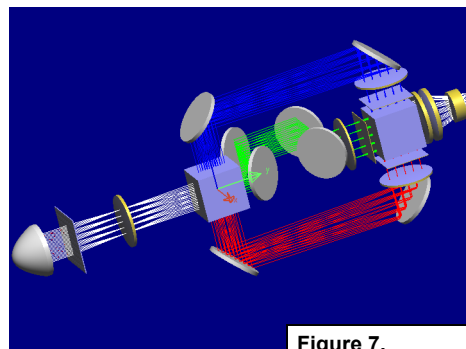

Figure 7. Digital Projection Illumination System

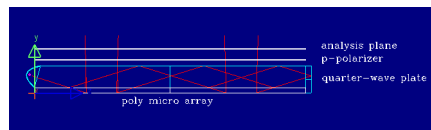
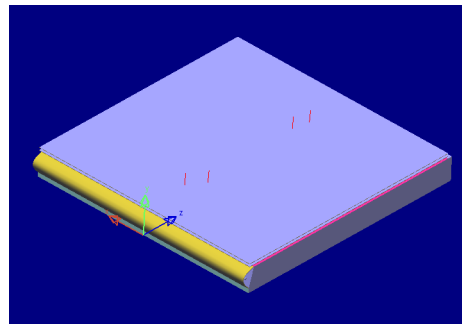

Figure 8. Flat Panel Display Backlight

Real World Problems

The polarization ray tracing and user-defined optical coating capability in *LightTools* can be used to design and analyze complex illumination systems such as a digital projection system shown in Figure 7 and a backlight for a flat panel display (FPD) shown in Figure 8.

In the projection system, a measured source can be used to illuminate a “fly’s eye” lens array which, combined with a dichroic coated x-prism, creates a uniform distribution of red, green, and blue light at three separate liquid crystal displays (LCDs). The three paths of light are then recombined using a second x-prism and focused into the pupil of an imaging lens system.

The LCDs can be described using a Jones or Mueller matrix and can be located between two crossed linear polarizers for contrast analysis.

The FPD backlight system shown in Figure 8 features a complex multi-layer

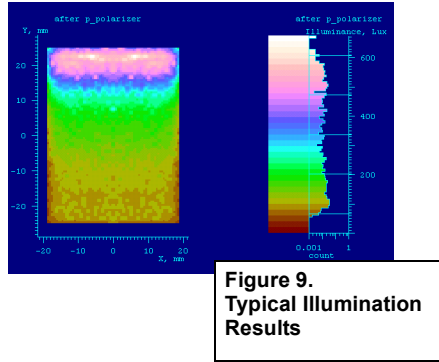

Figure 9.
Typical Illumination Results

coating that transmits p-polarized light, but reflects s-polarized light. The p-polarized light that passes through the coating is reflected off the bottom surface of the backlight and out of the system. The bottom surface is made up of a prism array with feature sizes on the order of 20 microns. The array was created using the *LightTools* Macro capability, which can be easily programmed to create such objects.

The s-polarized light reflects down the light pipe until striking the quarter-wave

retarder and mirror combination along the back wall of the light pipe. This changes the polarization from s to p (see Example 1) and allows the light to pass through the dichroic coating, off the micro prism array, and out of the light pipe. A complete analysis with an extended volume source and polarization effects can be performed. Figure 9 shows the illuminance across the FPD.

References

1. Fowles, Grant, *Introduction to Modern Optics* (Dover, New York, 1975), pp. 22-31.
2. Fowles, Grant, *Introduction to Modern Optics* (Dover, New York, 1975), pp. 51-52.
3. Oishi, Noriji, Mitsubishi Rayon Co., Ltd., Tokyo, Japan. *Polarization Forming Optical Device and Polarization Beam Splitter*. 1992. U.S. Pat. 5,124,841.

OPTICAL RESEARCH ASSOCIATES

3280 East Foothill Boulevard, Pasadena, California 91107
Phone: (626) 795-9101, FAX: (626) 795-0184
E-mail: service@opticalres.com, Web Site: <http://www.opticalres.com>