

How long does it take to trace a million rays? The answer depends on the nature of the model and the speed and resources of your computer. Since you probably can't upgrade your computer every time your model becomes more complex, you will want *LightTools* to trace rays as efficiently as possible. You can easily control *LightTools* to balance the need for accuracy of the results with speed of the calculations. This paper provides an overview of *LightTools* settings that can save you a significant amount of simulation time.

The most important controls to significantly impact the ray trace speed are:

- Accelerated Ray Tracing
- Source Starting Point Classification
- Repairing Imported Geometry
- Probabilistic Ray Splitting

The discussion below explains how and when to use these crucial controls in *LightTools* to improve the efficiency of ray tracing. We will use a sample projection system and a sample backlight system as examples. These systems are shown below in Figure 1 and Figure 2. In both cases, all refractive surfaces are set to consider Fresnel reflections.

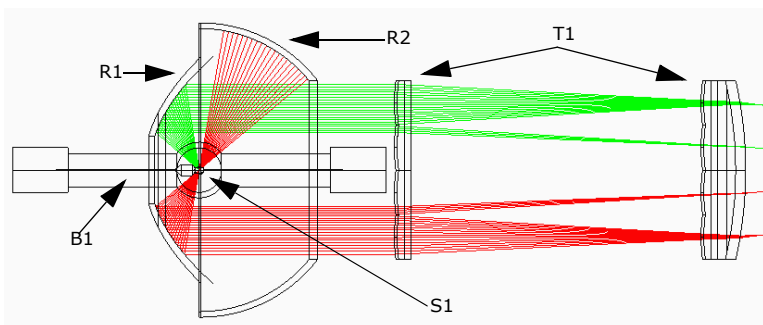

Figure 1. Projection system used for ray trace acceleration examples with components labeled:

- Rear reflector (R1) - imported spline (parabolic)
- Front reflector (R2) - imported spline (spherical)
- Tandem lens array (T1) - imported
- Bulb geometry (B1) - imported
- Cylinder source (S1) - native to *LightTools*

The green rays reflect from the parabola (R1) and propagate to the lens array; red rays reflect from sphere (R2), go back through source (S1), then reflect from the parabola (R1) and propagate to the lens array.

Red rays strike sphere and reflect back through source to the parabola and exit.

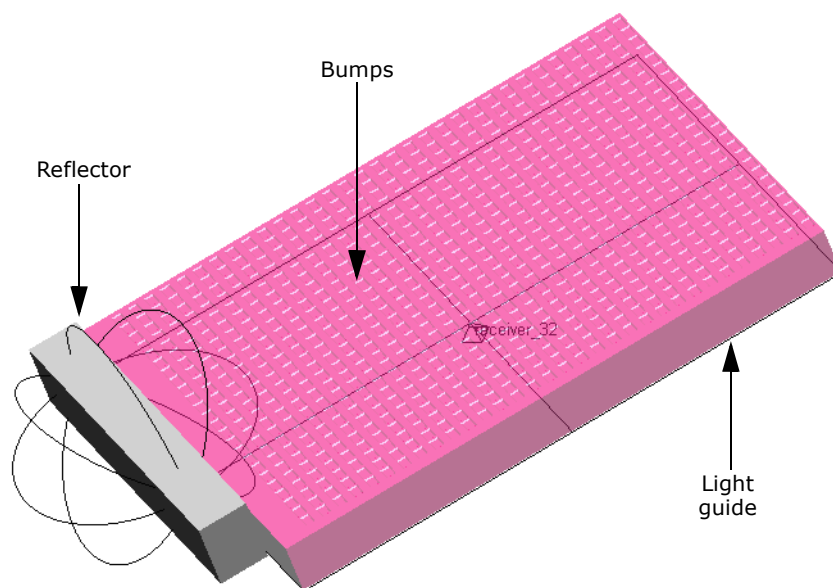

Figure 2. Backlight system used for ray trace acceleration examples. Reflector and Light guide were imported from a CAD system and contained 3846 spline surfaces. Many of these splines are bumps on the bottom of the backlight. Cylinder source is native to *LightTools*.

The table below summarizes the effect of ray trace controls for the two systems described above. The numbers shown in “**With**” and “**Without**” columns indicate the number of rays

traced per second. For Source Starting Point Classification, “**With**” = **Semi-Automatic** and “**Without**” = **Automatic**.

Speed Improvement Examples							
		Projection System			Backlight System		
LightTools Control	Critical for	Rays / sec		Improve Factor	Rays / sec		Improve Factor
		Without	With		Without	With	
Accelerated Ray Trace	1. Imported geometry 2. Spline (“Generic”) surfaces	357	5000	14.0	400	1667	4.17
Repair	1. Imported geometry 2. Spline (“Generic”) surfaces	34	45	1.32	37	125	3.38
Source Starting Point Classification	1. Imported geometry 2. Source(s) immersed in medium	16	34	2.13	30	37	1.23
Probabilistic Ray Split	1. Systems with Split surfaces (e.g., light guides with Fresnel loss) 2. Scattering surfaces which both transmit and reflect	45	357	7.93	125	400	3.20
Total Ray Trace Speed Improvement Factor		312			55.5		

From this table, it is clear that the proper use of ray trace controls can result in dramatic performance improvements. Next, each of these controls is described in more detail.

Accelerated Ray Tracing

Accelerated ray tracing is most beneficial when your model contains geometry imported from another CAD package or spline (“Generic”) surfaces. The accelerated ray trace mode includes many enhancements to the ray tracing algorithm. Typical ray trace speed improvements can range from 4X to 150X, depending on the nature of the model.

The only disadvantage to accelerated ray tracing is that it can cause a slight decrease in accuracy due to surface approximations. In order to handle a wide range of systems, *LightTools*

provides control of the ray trace mode at both the model and the individual component levels. This allows you to use the precision ray trace for imaging (or critical) components and accelerated ray trace for less critical illumination components.

The model-level control is found under the View > Preferences menu by selecting **General Preferences > Ray Trace**. The default is “Precision Ray Trace.” When “Accelerated Ray Trace” is selected, you can use the slider to select the desired speed/accuracy setting. If you then want to adjust the ray trace mode of an individual entity, select the object and open its Properties dialog box. At the top level, select the Ray Trace tab and check “Override Global Ray Trace Settings” and set the desired ray trace mode for that object. Figure 3 illustrates the location of these controls in the *LightTools* user interface.

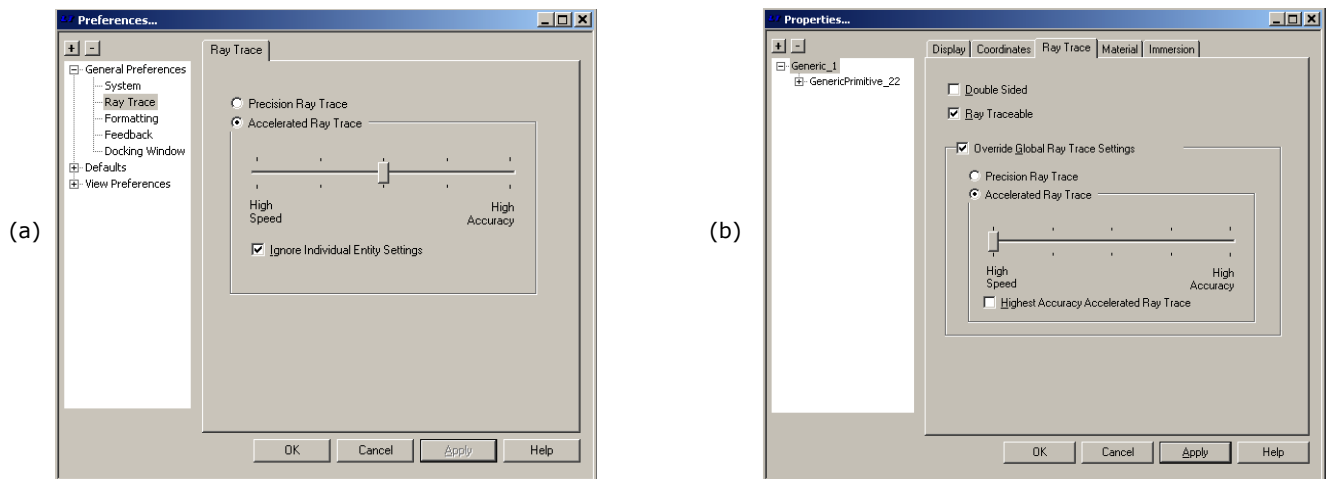

Figure 3. The accelerated ray trace controls. The global control (a) affects the entire model. The individual controls (b) can be used to override the global settings for an individual object.

Repairing Imported Geometry

The repair feature is critical when ray tracing imported geometry and spline (“Generic”) surfaces. During data exchange, most CAD systems represent geometry using spline surfaces, even if the surface shape can be described by an analytic equation. The *Repair* command analyzes the surfaces and converts spline surfaces to simple analytical surfaces (planes, spheres, cylinders, toroids, etc.) when possible. These substitutions can produce significant ray trace speed improvements.

“Repair” is accessed under the **Edit > Imported Geometry > Repair Selected Geometry** menu choice. It is also available from the 3D Editing palette as shown in Figure 4.

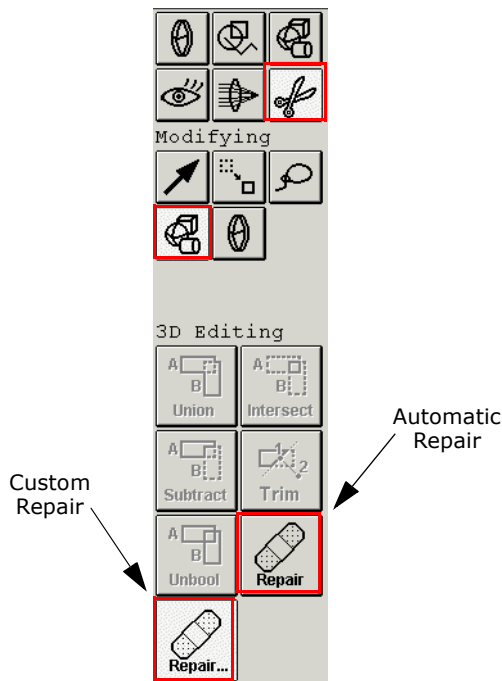

Figure 4. Command buttons to access Repair feature

Source Starting Point Classification

When tracing rays from sources during an illumination simulation, *LightTools* must first determine the material in which the ray starting point resides. This “Starting Point Classification” process can be time consuming for imported objects, objects with spline surfaces, or very complicated objects.

LightTools evaluates the bounding boxes of the objects in the model as it determines the material for the ray starting point. The bounding box is the virtual minimum volume that encompasses an entire solid object. Multiple bounding boxes can overlap a source as shown in Figure 5. To determine the material for the ray starting point, *LightTools* first must detect if the starting point falls within any of the bounding boxes in the close vicinity. If the ray falls within one or more bounding boxes, *LightTools* must then decide if the starting point is within the solid object associated with each bounding box.

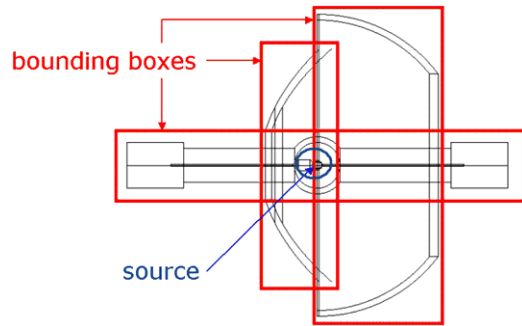

Figure 5. Source location resides within multiple bounding boxes of objects in Projection System example.

In order to handle a wide range of situations, *LightTools* provides several options to control how the starting point classification calculation is done. The starting point classification for a source is found on the “Emittance” tab of the properties dialog box at the top level of the source, as shown in Figure 6.

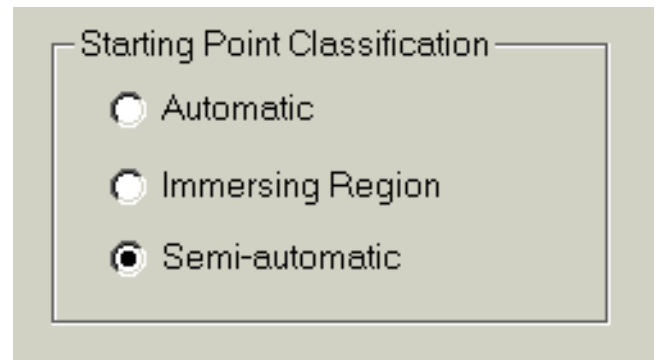

Figure 6. Input choices for source starting point classification

The behavior of each option is as follows:

- **Automatic** – *LightTools* does a rigorous calculation for all rays to determine the starting medium.
- **Immersing Region** – Starting material is set to the immersing object’s material (default is air); no additional computation time is required.
- **Semi-Automatic** (default) – *LightTools* uses less than 10 sample points to determine the media. If all of the sample rays begin in the one medium, *LightTools* uses that medium for all rays; the subsequent ray trace is identical to “Immersing Region” mode. If some rays begin in a different medium, *LightTools* reverts to Automatic mode.

Semi-Automatic mode is appropriate for most systems. The Immersing Region option is preferable when the source is either immersed in a single medium or is in air. The Automatic mode is appropriate when different portions of the source reside in different media.

Probabilistic Ray Split

Many systems include surfaces where part of the incident beam is transmitted and part is reflected. This can occur with an uncoated optical surface where Fresnel loss is specified and the Ray Trace Mode is set to “Split.” It also can occur on scattering surfaces where the Ray Propagation Direction is specified as both reflected and transmitted. A single ray incident on a split surface produces two rays that are propagated, often with vastly different powers. If the split surface is encountered multiple times, an exponential growth of rays can occur, dramatically increasing the ray tracing time.

The Probabilistic Ray Split control provides for an efficient ray trace by tracing only one outgoing ray for each ray incident on the split surface. *LightTools* uses a probabilistic approach to determine whether the incident ray is reflected or transmitted. For example, consider a split surface of reflectance R and transmittance T. The probabilities that a ray will reflect or transmit are calculated as:

$$\text{probability to reflect} = \frac{R}{R + T}$$

$$\text{probability to transmit} = \frac{T}{R + T}$$

Similar probability calculations are performed for other settings such as Fresnel Loss or user coatings. Note that this approach works well only when you trace a large number of rays. For a small number of rays, the system will be under sampled by tracing almost all rays in the more probable direction. Because of the potential for under sampling by a small number of rays, probabilistic ray splitting is not appropriate for stray light analysis.

We can use a simple example to illustrate probabilistic ray splitting. Let us take a planar surface, and set the optical properties of the split zone as shown in .

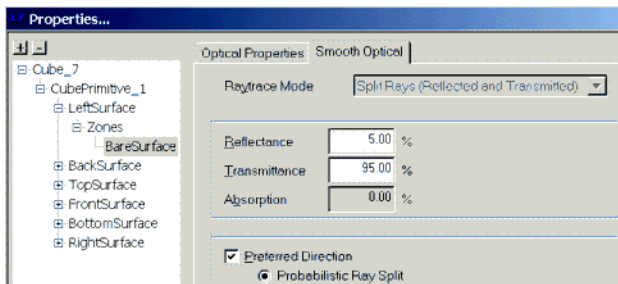

Figure 7. Settings for split rays with probabilistic ray split on smooth optical property zone.

Using the Probabilistic approach, when 100 rays are incident on this surface, roughly 95 rays are transmitted and 5 are reflected. When the Probabilistic ray split is disabled by unchecking “Preferred Direction,” the surface acts a simple

split surface: 100 incident rays produce 100 transmitted rays and 100 reflected rays. These two cases are shown in Figure 8. In both cases, the total power in the transmitted direction (or reflected direction) is the same.

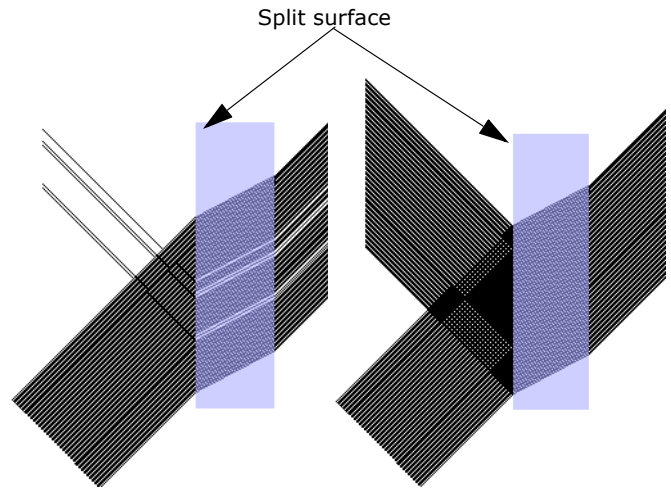

Figure 8. Ray Trace through a split surface with (a) probabilistic ray splitting; (b) simple ray splitting

In many systems, the ray splitting can result in a significant growth in the number of rays. Figure 9 shows a light guide where all zones have the ray trace mode set to split. A single ray enters the light guide as shown by the arrow. With the simple ray splitting (a), the ray splits every time it enters or exits the light guide and each resulting ray can split further. With the probabilistic approach (b), there is no ray splitting; one ray enters the model and one ray exits.

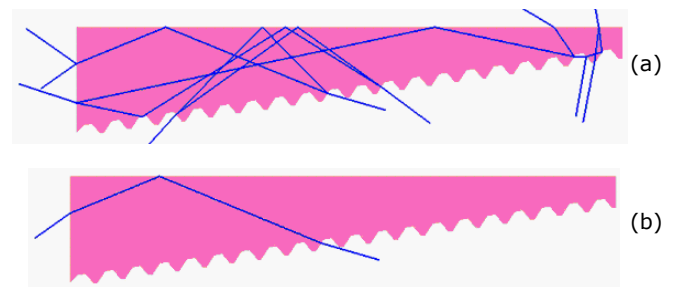

Figure 9. Light guide with a single incident ray and (a) simple ray splitting; (b) probabilistic ray splitting.

Other Controls Impacting Ray Trace Efficiency

In addition to the previously discussed settings, other controls can also affect the ray trace performance. Two of these settings are described briefly.

- **Simulation Update Interval**

The update interval specifies when the results of a simulation are updated; it is accessed under the **Illumination > Simulation Info** menu. After the specified number of

rays is traced, the graphical output windows including views, charts, tables and dialog boxes are updated. The update interval can have a significant impact on simulation time when there are large receiver meshes (over 100 x 100 mesh bins) or CIE meshes defined in the model. Therefore, the most efficient ray trace occurs when “Update Results After” is set to “Total Rays” as shown in Figure 10.

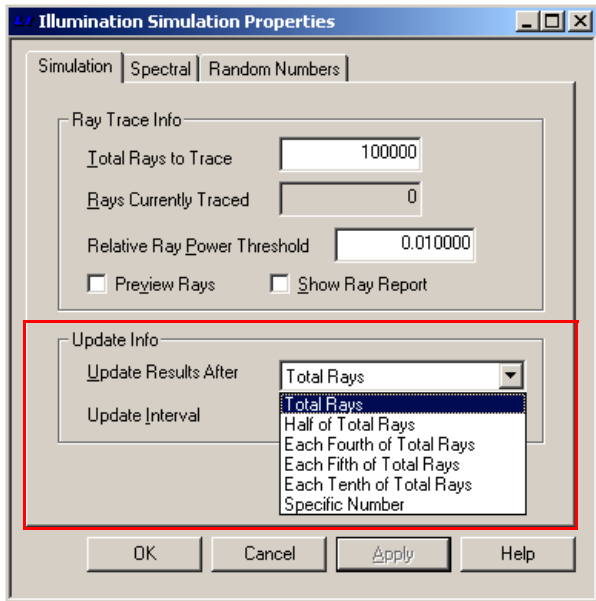

Figure 10. Selection of “Total Rays” for the simulation update interval.

- **Number of Scattered Rays**

The “Number of Scattered Rays” control shown in Figure 11 is very important for models with scattering surfaces. For simulation purposes this control should always be set to 1 so that *LightTools* generates a single

scattered ray for each incident ray. You must be sure to trace an adequate number of rays to sample the entire distribution. When the number of scattered rays is set greater than 1, *LightTools* generates the specified number of rays per incident ray. This setting is appropriate when the model is being evaluated using NSRays as it more clearly illustrates the scattering distribution.

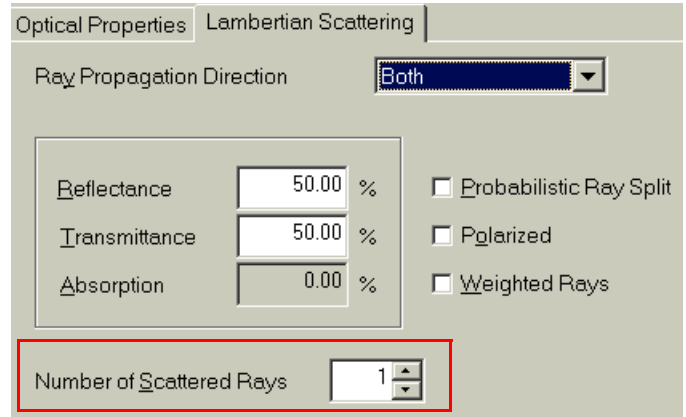

Figure 11. Number of scattered rays control for a Lambertian scatterer.

Recap

LightTools provides a variety of controls that impact the illumination simulation time. Accelerated ray tracing, proper source starting point classification, repairing imported geometry, and maintaining “1 ray in/1 ray out” with probabilistic ray splitting and a single scattered ray can substantially increase the number of rays traced per second. In addition to these model-specific controls, allowing the simulation to proceed without update interruptions also improves ray tracing speed. Judicious use of these controls allows you to achieve accurate simulation results most efficiently.

O P T I C A L

R E S E A R C H

A S S O C I A T E S

3280 East Foothill Boulevard, Pasadena, California 91107
Telephone: (626) 795-9101 FAX: (626) 795-0184
E-mail: service@opticalres.com Web site: <http://www.opticalres.com>