



# Application-Specific Optical Design

## Introduction

Optical design software capabilities have advanced considerably from the late 1950s and early 1960s when computer tools first became available. Initially, the main purpose of the software was to geometrically trace rays and perform limited analyses. However, the introduction of automated optimization, generally using a damped least squares algorithm, is what has made software an indispensable tool for the optical engineer.

Today, optics are used in a variety of applications, and unique features and capabilities are often required to model, optimize, and analyze systems designed for a specific application. In this paper, we will look at several different application areas and discuss some of the software modeling, design, and analysis features important for those applications. The applications include:

- Commercial Imaging Systems
- Visual Systems (i.e., optical systems that use the human eye as the detector)
- Off-axis tilted and decentered Systems
- Telecommunications Systems
- Astronomical applications
- Non-visible Systems (e.g., UV, IR, etc.)
- Microlithographic (Optical Stepper) Systems

Figure 1 shows a montage of several CODE V models used in different application areas.

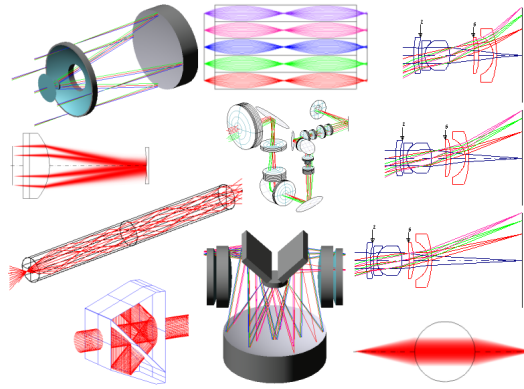

Figure 1. CODE V Models for Different Applications

## The Optical Design Process

Before discussing specific applications, it is important to consider the optical design process, since the general process is common across all applications. The process can be summarized as follows:

### 1. Develop a design specification.

This includes 1<sup>st</sup> order properties (Effective Focal Length, Field of View, F/number, spectral band), size and weight limitations, material and surface shape limitations, nominal performance metrics and “as-built” requirements (i.e., the performance of an actual system with fabrication and assembly tolerances), along with any other restrictions or issues that will impact the final optical design. Design specifications are strongly driven by the specific application.

### 2. Determine one or more starting points.

Optical engineers rarely develop a starting design from scratch. Based on the design specification, engineers typically use

the patent literature or some other database of refractive, reflective, or catadioptric forms to find configurations that might be successful in meeting the design specifications for their specific application. One technique that can be used successfully in developing a starting point for a complex system is to break the system functionality into sub-systems of recognizable forms. For example, a scanning system may consist of a pre-scan objective lens configuration with a post-scan eyepiece configuration. In recent years, the introduction of “global optimization,” such as CODE V’s proprietary Global Synthesis<sup>®</sup> algorithm, have allowed optical engineers to more fully search the solution space for useful starting configurations. Typically, designers find one or more promising forms from prior experience or the patent literature; and use these as starting points for global optimization. The purpose at this stage of the process is not to generate a final complete design; rather, it is to find multiple starting forms with unique characteristics.

### 3. Analyze the starting design(s).

The types of analyses performed depend on the application and design specification. The purpose of this step is to determine how close the initial design(s) is to meeting the final design specification.

### 4. Optimize the starting design(s).

This step includes determining the possible variable parameters in the system model that can be modified to improve performance, generating the appropriate merit function and

constraints based on the design specification, and then optimizing the design forms.

**5. Analyzing the optimized design(s).**

This step is similar to Step 3, but should include an initial tolerance analysis to determine if the current form will be sensitive to manufacturing and alignment errors. CODE V includes a tolerance analysis capability based on very fast and accurate wavefront differential algorithms. This feature includes the impact of a single or multiple compensators used to recover lost performance, and will determine tolerances (within user-defined limits) in order to minimize total performance loss. This capability allows for very fast initial assessments of design sensitivity to fabrication tolerances and assembly errors. This type of analysis helps the designer determine the best design form(s) for their specific requirements. Other required analyses may include determining the performance loss due to environmental conditions such as temperature or pressure. At this point, designers can begin to choose the best candidates from among competing design forms.

**6. Repeat Steps 4 and 5 as necessary.**

Optical design is an iterative process. It is rare that the initial optimization of a starting form results in the final configuration. Typically, designers need to modify the model by allowing additional variables (e.g., adding lenses, using aspheric surfaces, etc.), or by allowing more freedom during optimization by relaxing constraints. If the optical materials are allowed to vary, the designer will need to substitute obtainable materials for any theoretical material definitions and perform a quick re-optimization before evaluating the system. Sometimes, if the resulting design does not meet the design specifications, the designer must revisit the specifications to determine if they can be modified with regards to size and weight limits, or performance goals.

**7. Perform a global optimization**

**check on the finished design.** Since the constraints, variables, and specifications have likely evolved during the optical design process, it is often useful to perform another global optimization (Global Synthesis) with the finalized parameters. If global optimization does not generate a form better than the current design, this gives designers some confidence that their final design is the best solution. Occasionally, when starting from the "final" configuration, global optimization will find a configuration that does a better job of meeting the performance goals. If the optical materials were allowed to be variable during Step 4, this should also be allowed during this step, and real glass substitution will be required on the resulting designs.

**8. Perform a tolerancing check on**

**the finished design.** In this step, the designer should determine the final tolerances and compensators for the design. The designer should already be working with the opto-mechanical engineer to understand what adjustments are possible. Once again, using the wavefront differential method of tolerancing allows different compensation schemes to be tested very quickly. In addition there are features that allow the software model to match the opto-mechanical implementation (i.e., "labeled" and "grouped" tolerances and compensators). An aspect of this step that is often overlooked is to always include an adjustment tolerance on the compensator. In the real world, no compensation (such as refocus) can be achieved perfectly; there is always some error in the adjustment (e.g., due to thread tolerances on a focus barrel).

**9. Modify the finished design for fabrication and cost considerations.**

Once a final design form is determined, there are additional steps that will facilitate the fabrication of the design and potentially lower life-cycle costs. These steps may include:

- Verify the availability of optical materials in the finished design. In recent years, glass manufacturers have been trying to keep costs low by maintaining only small inventories of infrequently ordered glasses. When this happens, a glass that is offered in the manufacturer's catalog is sometimes out of stock. This can often require a complete redesign to use different optical materials for time-critical designs. The designer should verify material availability as soon as they have a reasonable idea of which materials are required.
  - If possible, make bi-convex and bi-concave lenses with similar radii equi-convex or equi-concave to prevent them from being assembled backwards. This happens more often than fabrication shops would like to admit.
  - If possible, make spherical surfaces with long radii planar.
  - If possible, round lens thickness values to a limited number of significant digits (this will make the fabrication shop happy).
  - Adjust the radii in the design to match the test plates available to the fabrication shop. This step will save fabrication cost if test plates are being used to verify the manufactured radii. CODE V optimization supports automatic test plating to an input test plate list.
  - After all these changes have been implemented, perform a final optimization and performance evaluation(s) (both nominal and as-built).
  - Create and check lens and component drawings for the fabrication facility.
- 10. Post-fabrication analyses.** After the design has been fabricated, there may be some additional steps necessary for precision applications:
- The glass model for the design may need to be altered to match measured index data from samples of the real material to be used, and the airspaces adjusted slightly to

compensate for performance changes due to the refractive index differences. This process is called “melt fitting,” and CODE V includes some special features to aid in the modeling of measured glass data.

- Apply surface deformation data, measured with an interferometer directly to the surfaces in the model. Most commercial interferometer manufacturers can export the measurement data directly into CODE V’s interferogram file format.
- Apply measured lens thicknesses to the model.
- After these changes have been implemented, analyze the system “as-built” performance based on the information.
- If needed, you can perform automated alignment on the design. CODE V contains an “Alignment Optimization” feature that can be used to determine the correct alignment adjustments based on optical system measurements using an interferometer.

With the optical design process outlined, we can examine how the specifics of the process can vary for different applications.

## Commercial Imaging Systems

Imaging systems for commercial applications (such as camera objectives and projector lenses) were one of the earliest application areas that benefited from optical design and analysis software. These systems cover a large range of f-numbers (F/#) and Fields of View (FOV).

Commercial imaging systems commonly use centered, rotationally symmetric refractive systems. A starting point could be chosen from one of the 2400 patents in CODE V’s built-in patent database, or by using global optimization. The applicability of global optimization for starting point generation can be seen in Figure 2. The appli-

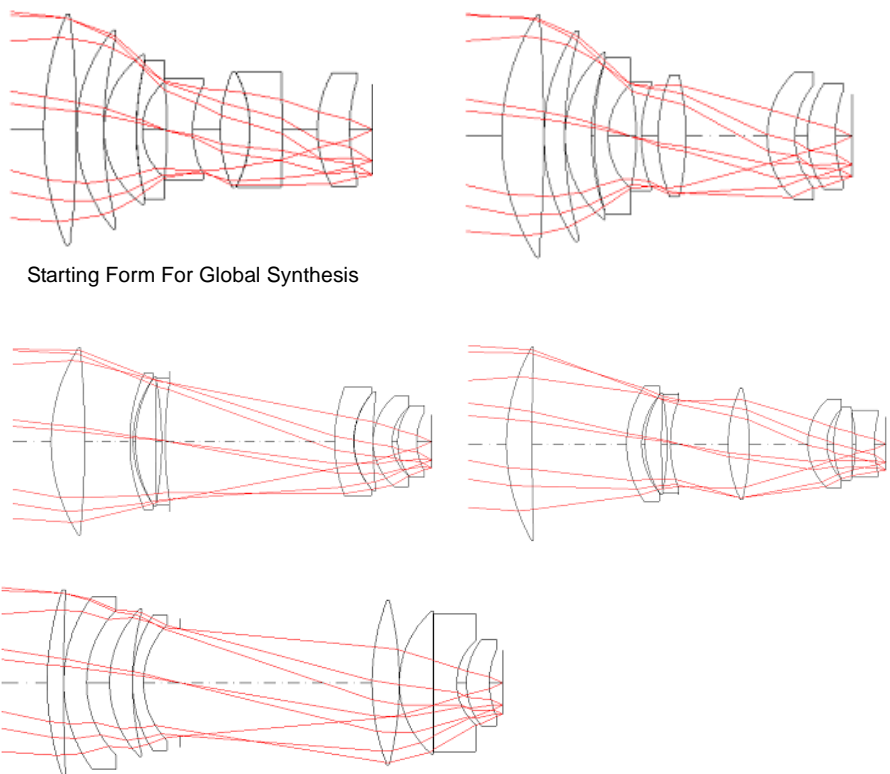

Figure 2. Several distinct solutions for a CRT camera lens, generated by Global Synthesis

cation is a 200 mm EFL, F/1.25, all-spherical, 8-element, camera lens for photographing a CRT display. The starting configuration is indicated.

Early imaging system performance metrics were based on geometrical ray tracing and included ray aberrations, geometrical Modulation Transfer Function (MTF), 3<sup>rd</sup> and higher-order aberrations. Later, as diffraction computations were added to software, the standard performance metrics migrated to Diffraction MTF, Root-mean-square (RMS) wavefront error, Point Spread Functions (PSF), and Strehl ratios. Figure 3 shows a mosaic of performance analysis results for a Petzval lens system.

Since diffraction-based MTF is a leading performance metric for commercial imaging systems, optimization and tolerance metrics that compute diffraction-based MTF can be very beneficial. CODE V’s fast and accurate wavefront differential algorithm is used for both MTF optimization (i.e., an optimization merit function that directly optimizes

diffraction-based MTF at specified frequencies) and MTF tolerancing.

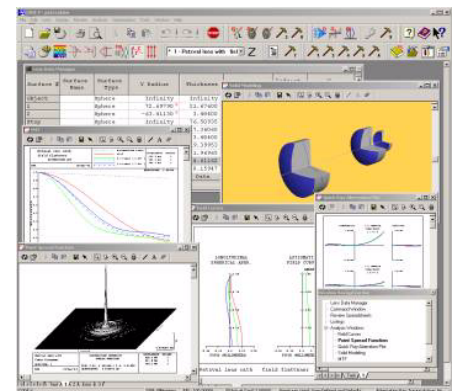

Figure 3. Several Analyses for a Petzval Lens

## Visual Systems

The effective design and analysis of visual systems can benefit from specialized handling of the light emerging from the system. In a visual system, the human eye is the detector; and it has a built-in capability to quickly refocus as it scans a field of view through an opti-

cal system. This suggests that optical software needs to model independent focus across field. Typically, the focusing ability of the eye is measured in units of diopters of accommodation. A diopter is a reciprocal unit of distance, corresponding to  $1/(\text{distance in meters})$  to where an object appears to be. A person with good vision (i.e., emmetropic vision if corrective eye glasses are not required, or possibly myopic or hyperopic vision if corrective lenses are needed) can focus very comfortably at infinity. Focusing on an object that appears to be at infinity corresponds to an accommodation of 0.0 diopters (i.e.,  $1/\infty$  meters).

Since the average human has a visual resolution that corresponds to about one arc-minute, performance metrics in terms of angular units are natural for evaluating visual systems. Some typical visual system performance metrics and suggested goals are:

- Field curvature < 1 diopter (always positive, i.e., the image is formed in front of the observer since the human eye has limited ability to focus light converging towards it)
- Astigmatism < 0.25 diopter
- Lateral color < 5 arc minutes (assumes modeling of a full photonic spectral band, ~ 465 to 645 nm)
- 0.25 MTF at 0.5 cycles/arc minute (corresponds to a “line width” of one arc minute)

CODE V supports a “true afocal modeling” feature that allows independent focus across field, with focus values defined in diopters of accommodation. The feature also supports aberration analysis output in terms of angular units,

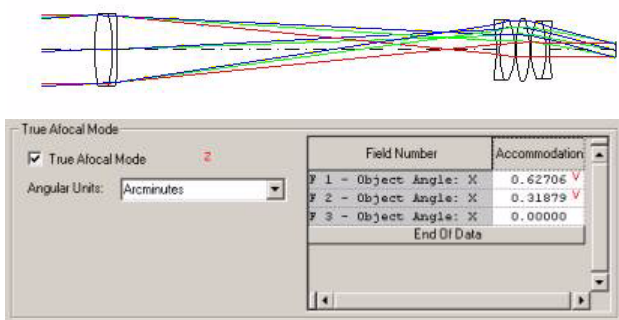

Figure 4. 5x40 Telescope & True Afocal Modeling Controls in CODE V

or cycles/angular unit in the case of MTF. Figure 4 shows a 5x40 visual telescope (i.e., 5x magnification, 40 mm entrance pupil diameter) and the CODE V controls for angular performance units and accommodation across the field of view (which can be variable for optimization).

Notice that each field has a separate accommodation ranging from 0.0 diopters at the edge of the field (i.e., objects at the edge of the field in the telescope appear to be at infinity) to +0.63 diopters on-axis (axial objects appear to be  $1/0.63$ , or about 1.6 meters in front of the observer. This range of accommodation meets the typical field curvature specification < 1 diopter.

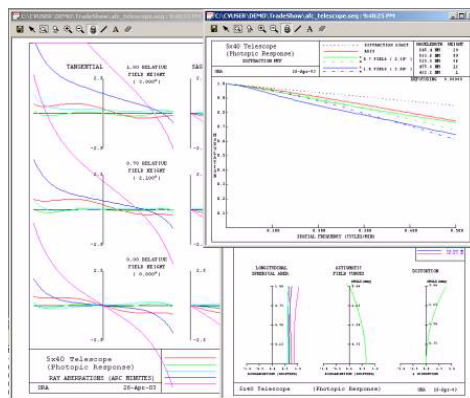

Figure 5. Analysis Curves with units of Diopters, Arc Minutes, or Cycles/Arc Minute

Figure 5 shows a mosaic of analysis output with units in arc minutes, or diopters of accommodation.

## Off-axis, Tilted, And Decentered Systems

Rotational symmetry has a number of benefits in an optical design, including symmetry of the aberration field and generally easier fabrication and alignment. However, many applications require the symmetry to be violated, especially to meet packaging constraints. Space-borne reflective optics and heads up displays (HUDs) can often be fit into a much smaller space if the components are tilted and decentered relative to a common axis.

For these types of systems, flexibility in how the tilts and decenters can be defined is an important software modeling feature. For example, CODE V supports six different methods for tilting and decentering a surface, and defining the coordinate system that follows the surface. One of the most useful is the ability to define all the surfaces relative to a global coordinate system.

For optimization, control of beam and component clearances becomes very

important.

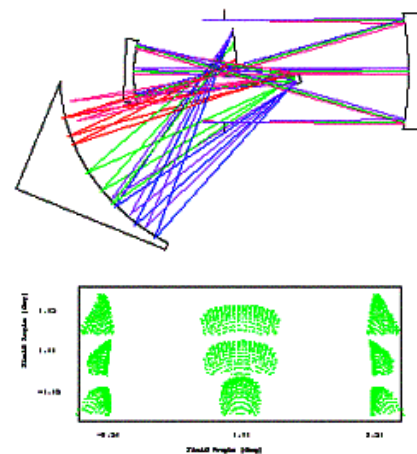

System Layout and Full Field Spot Diagram - Before Optimization

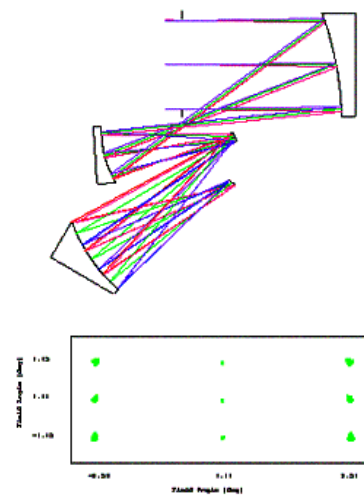

System Layout and Full Field Spot Diagram - After Optimization (same scale)

Figure 6. 4-Mirror, Off-axis System, Before and After Optimization

important, since the natural tendency is for the design to become more symmetric to reduce aberrations, and this often leads to interference problems between the ray bundles and components.

Figure 6 illustrates the evolution from a starting system with multiple beam and component interference problems to a final system with improved performance and no beam and component interference problems. This design evolution was accomplished in a single optimization run. The key to the successful optimization of this system was the ability to easily define optimization constraints to automatically prevent interference problems. In CODE V, these constraints are typically handled as Lagrange multipliers, which means they are separate from the optimization error function (in this case, the default RMS blur size error function). This allows the optimization to converge on the best performance in the least constrained mode, while maintaining packaging clearances.

Another important aspect for the design of systems utilizing off-axis tilted and decentered components, is that traditional diagnostic analyses, such as transverse ray aberration curves or field curves, can be deceiving. These traditional tools were developed for systems with rotational symmetry, and rely on this symmetry to be meaningful across the entire field of view. To address this limitation, CODE V includes a field map diagnostic option that can plot various performance metrics across the full field of view. The information in these plots can provide great insight on what steps to take to improve the system performance (see Thompson 1996:2 and Rogers 1999:286). Figure 7 shows two

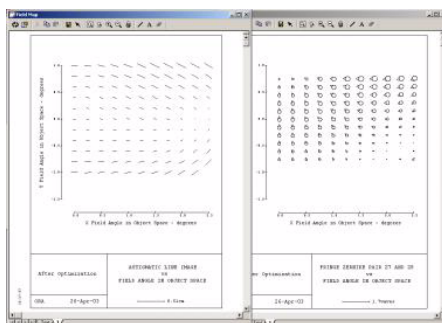

Figure 7. Full Field Maps of Aberration Fields

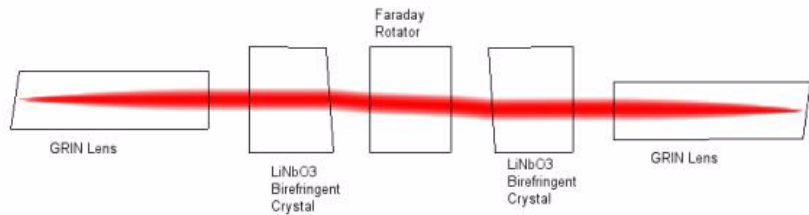

Figure 8a. Optical Isolator System

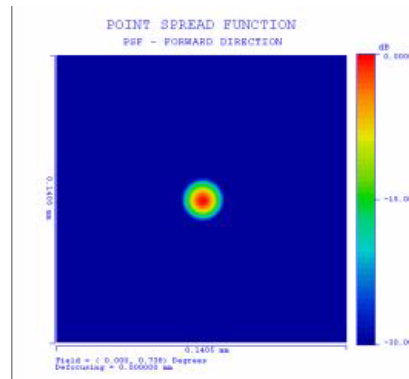

Figure 8b. Field Intensity at Output Fiber

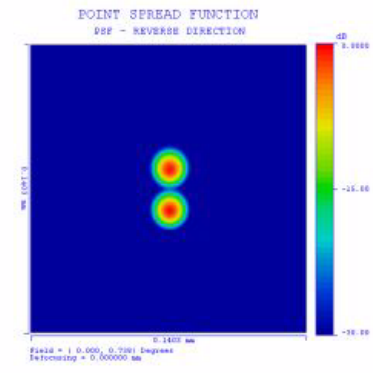

Figure 8c. Field Intensity at Input Fiber from Reflection at Output Fiber

field map outputs for the system above, one showing astigmatic focal lines and the other a plot of the magnitude and orientation of wavefront Zernike coefficients for 3<sup>rd</sup> order coma.

## Telecommunication Systems

In recent years, there has been an increase in the optical design and analysis of components for telecommunication systems. These components are generally very small. The governing performance metric is how much energy is gathered from an input fiber, laser, or waveguide and coupled into an output fiber. As a percentage this is called the fiber coupling efficiency, but it is typically defined in terms of energy loss in decibels (i.e., insertion loss).

The fibers are very small and typically can propagate a single mode, or only a few modes. Gradient index elements are common and polarization effects are often important. Figure 8a shows an optical isolator. The input fiber is on the left and the output fiber is on the right. For this system, it is desired that light reflected from the output fiber face will not propagate back into the input fiber.

This system has very little insertion loss in the desired direction (the intensity of the optical field at the output fiber is shown in Figure 8b). By using birefringent crystal materials and a Faraday rotator element to rotate the electric field, any light that is reflected back towards the input fiber is split into two components, such that very little energy couples back into the input fiber (Figure 8c).

Typical analysis models for traditional imaging systems treat all diffraction as occurring at the optical system exit pupil. This may be inadequate for telecommunication systems, since the beams are typically only a few hundred wavelengths in diameter and often propagate several thousand wavelengths in distance between components. The physics of this arrangement cause the beam diameter to grow due to diffraction spreading, and cannot be accurately modeled with geometric ray tracing techniques. In this case, general beam propagation algorithms must be used throughout the entire optical system to adequately account for diffraction.

CODE V's general beam propagation feature can be used to determine the

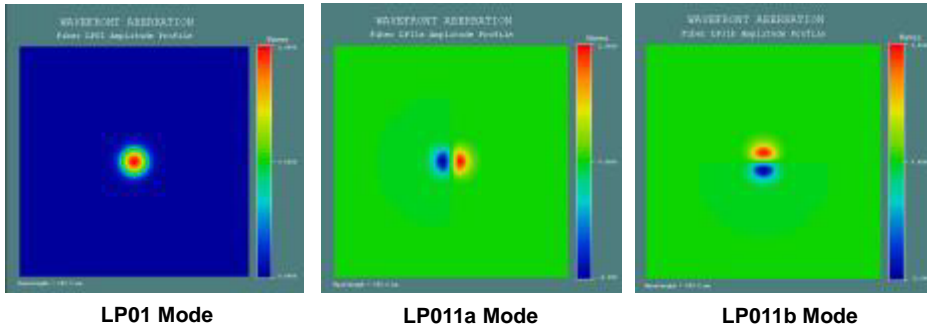

Figure 9. Supported Modes for Corning SMF-28 Fiber used at 850 nm

complex field throughout the system, and, most importantly, at the output fiber face. CODE V's fiber coupling efficiency feature calculates the overlap integral between the complex field and the mode profile of the single mode fiber to determine the insertion loss into the fiber. Multimode fiber analysis is also supported, by computing the coupling efficiency into each supported mode of the fiber. Figure 9 illustrates the amplitude profile for three modes supported by a Corning SMF28 fiber operating at a wavelength of 850 nm.

Typically, this fiber is used at 1310 nm or 1550 nm, and only the fundamental mode (LP01) will propagate. However, when used at 850 nm, the modes shown in Figure 9 are supported. The data used to create these plots is used to define the mode structure for the multi-mode fiber coupling efficiency calculation.

CODE V supports both a fiber coupling efficiency merit function for optimization and a coupling efficiency tolerancing performance metric. This allows the optical design process outlined on page 1 to be directly applied to these types of systems.

## Astronomical Applications

Astronomical applications generally require small fields of view, fast (small F-number) optics, and point image performance metrics, since the objects of interest are small and faint. In addition, many large telescopes and planned space-borne optics are using segmented apertures. Traditional optical system

modeling defines systems sequentially for ray tracing. That is, all rays must go from an object to surface 1, to surface 2, to surface 3, and so forth. When segmented apertures are used, different rays will intersect different segments, but not intersect the others. In CODE V, this type of system is handled by using non-sequential surfaces (NSS). Figure 10a shows a stellar interferometer system used for ultra-high resolution studies. The path for the light from the two separated apertures is carefully maintained to be approximately equal so that the

beam remains coherent and interference results. The angular size of the object under observation can be inferred by adjusting the separation between the two apertures until the fringe structure disappears. Figure 10b shows the PSF in a well-aligned system. Since the mirrors are modeled as separate non-sequential components, they can be tilted with respect to each other. The effect on the PSF of a 1/3 arc-second tilt on one of the mirrors is shown in Figure 10c.

## Non-Visible (UV, IR, etc.) Systems

The optical design process outlined on page 1 works equally well for systems that operate at visible wavelengths and for systems that operate outside the visible spectrum. However, some new issues arise when operating outside of the visible spectral band. For example, systems that operate in the ultraviolet will require better optics to achieve "diffraction limited" performance, since diffraction is a function of wavelength

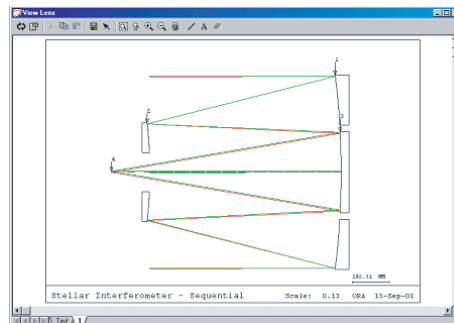

Figure 10a. Stellar Interferometer Systems

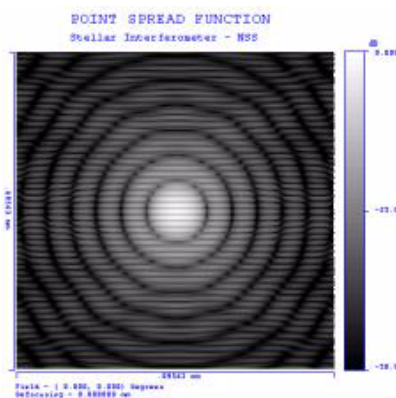

Figure 10b. PSF for Aligned System

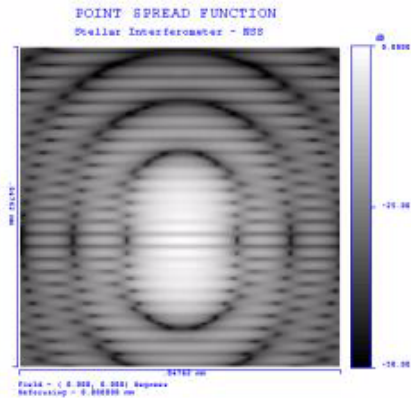

Figure 10c. PSF for Misaligned System

and shorter wavelengths allow better resolution.

Thermal infrared systems, designed to detect heat emissions from thermal bodies, typically use cooled detectors. Often, the detector array instantaneously images only a portion of the desired field of view. Using scan mirrors or other devices, the image of the detector array is scanned across the full field of view. These systems are subject to some unique image defects such as narcissus, which must be considered in the design specification.

In general, material considerations have the most significant impact when working outside the visible spectral region. Optical glasses eventually become opaque in the ultraviolet and infrared. Often other crystalline materials must be used. Reflective optics have the benefit of working across a larger spectral band but sometimes their use is restricted due to packaging considerations or fabrication limitations.

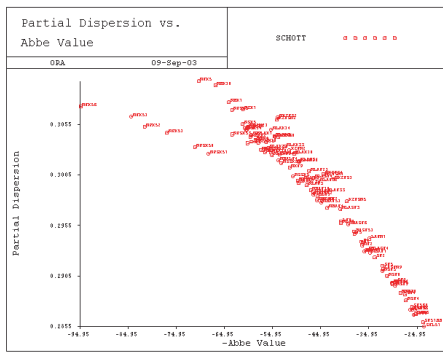

Figure 11. Plot of P vs. V for Optical Glasses in the Visible Spectral Band

In the near ultraviolet and infrared, optical glasses will transmit, but their optical properties will be different than when they are used in the visible. For example, in the visible spectral region, the 2<sup>nd</sup> derivative of the index vs. wavelength curve, represented by the partial dispersion (P), varies nearly linearly with Abbe number for most commonly available optical glasses. This representation is sometimes called “the normal dispersion line” and is useful for understanding glass selection to correct the aberration of secondary color. Figure 11 is a plot of the partial dispersion (P) ver-

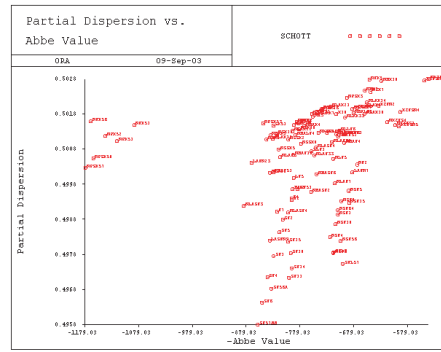
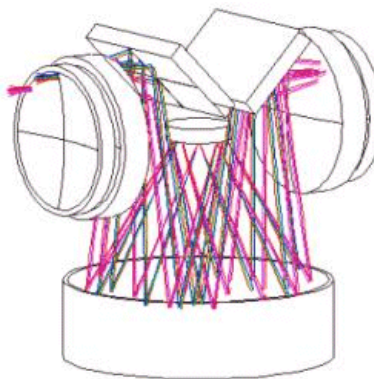

Figure 12. Plot of P vs. V for Optical Glasses in the 1550 nm – 1610 nm Spectral Band

sus Abbe number (V) for the Schott glass catalog, in the visible region.

Fictitious glasses, i.e., glass models that can be variable for optimization, are typically based on this normal dispersion model. However, outside the visible spectral region, the concept of a “normal line” may not exist. Consider the P vs. V plot for the same glasses operating in a typical telecommunications wavelength band of 1550 to 1610 nm. The result is shown in Figure 12.

A fictitious glass dispersion model based on the “normal line” in the visible would not do a very good job of modeling real glass dispersion behavior in the infrared. In CODE V, users can redefine the fictitious glass model wavelengths and dispersion characteristics to match those of real glasses used in that wavelength region. This makes it much easier to substitute real optical materials for variable optical materials.



## Microlithographic Systems

One of the most demanding optical design applications is microlithographic systems. These are systems used to fabricate integrated circuits. While the optical design process is the same, these systems require diffraction limited as-built performance with essentially zero distortion. Successive generations of these systems use shorter operational wavelengths and faster optics in order to achieve the improved theoretical resolution limit. Subtle image degradation due to material stress birefringence, intrinsic material birefringence, thermal effects, and other sources must be analyzed (Li, Ota, and Murakami 2003:127-129). In addition, the characteristics of the illumination beam must be considered. For example, CODE V can analyze one-dimensional and two-dimensional image structure assuming illumination that ranges from fully coherent to incoherent. Figure 13 shows an Offner reflective microlithographic system and image structure analysis.

The demands of microlithographic optics require that all possible steps be taken to maximize performance. The post-fabrication steps of the design process become critically important. Manufacturers have successfully used CODE V’s alignment optimization feature to reduce cost and improve performance (Sugisake, et al., 2000:751-758).

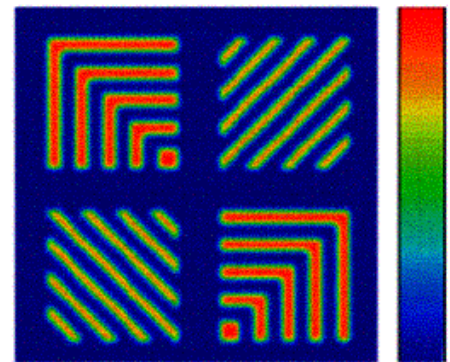

Figure 13. Offner 1:1 Microlithographic Projection system & 2-D Partial Coherence Analysis

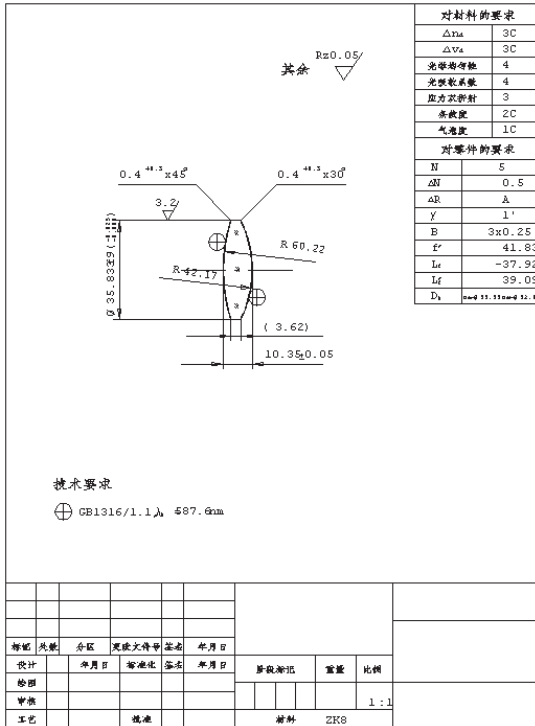

Figure 14

## Other Considerations

Engineering is an international endeavor, but different locales often require specialized tools. An example within CODE V is support of the PRC National Standard optical element drawing format. Figure 14 shows an optical element drawing for a singlet.

To this point we have not discussed optics for illumination design and analysis. The optical design problem for illumination systems is very

## Conclusions

The optical design process is relatively consistent across various applications. However, many applications require some specialized design or analysis techniques and features. Successful optical design requires that the designer always consider the design specification, which is the first and often the most important step in the optical design process. It is here that all the considerations and limitations of the design

mination systems is very different from that of image-forming applications. In some respects, it is much more difficult to develop an optical system that distributes light from a condensed source evenly across a large area (or with some specific distribution). An attempt to merge the capabilities required for both image-forming and illumination applications into a single software package, necessitates significant added complexity to the software interface, or a significantly reduced feature set. ORA has developed another software product, *LightTools*<sup>®</sup>, to address the specific needs of the illumination engineering field by providing a full set of features with an easy-to-use interface.

should be defined. The specification will affect the approach used in executing the optical design process, and help to determine what design features and analysis functions should be applied to the problem.

The benefits of optical design software encompass all phases and applications of optical engineering in the 21<sup>st</sup> century. The return on investment for outstanding software pays for itself many times over in terms of superior performance, lower manufacturing costs, and in its ability to facilitate technological innovation.

## References

Li, Yangqiu, Ota, Kazuya, and Murakami, Katsuhiko. "Thermal and structural deformation and its impact on optical performance of projection optics for extreme ultraviolet lithography," *Journal of Vacuum Science and Technology B*, Jan/Feb 2003, pp. 127-129.

Rogers, John R. "Design techniques for systems containing tilted components," *SPIE*, Vol. 3737, 1999, p. 286.

Sugisake, K., et. al., "Assembly and alignment of three aspherical mirror optics for extreme ultraviolet projection lithography," *Proc. SPIE*, Vol. 3997, 2000, pp. 751-758.

Thompson, Kevin. "Practical methods for the optical design of systems without symmetry," *SPIE*, Vol. 2774, 1996, p. 2.

# OPTICAL RESEARCH ASSOCIATES

3280 East Foothill Boulevard, Pasadena, California 91107

Telephone: (626) 795-9101 FAX: (626) 795-0184

E-mail: service@opticalres.com Web site: http://www.opticalres.com